

Detecting Oscillations in an ABB Variable Frequency Drive System (VFD) of large industrial Blowers

Date: May 25, 2011

Authors: Jürg Roth, ABB Switzerland, Peter Wilhelm, Elsys AG

Abstract

Many large industrial blowers such as Blast Furnace Blowers are steadily monitored for correct functioning over a long period of time with an advanced data acquisition system in order to capture reliably and securely any anomalies that may occur. In such a monitoring system, the unwanted events are captured by a multi-channel transient recorder whereas every channel is acquired and stored to disk independently. In a suitable data acquisition system every channel needs to be an active trigger source in an advanced trigger mode such as interval or slew rate in either AND or OR trigger logic.

The described trouble shooting instrumentation features remote accessibility of the data acquisition system whereas the setup as well as data collection can be done through Internet. This is especially useful in cases where the installation is not permanently manned or off the beaten track.

This Application Note describes measurements on a Variable Frequency Drive System installed in the steel industry. The purpose of the measurement is the investigation of the root cause of occasionally occurring oscillations.

Drive System Configuration

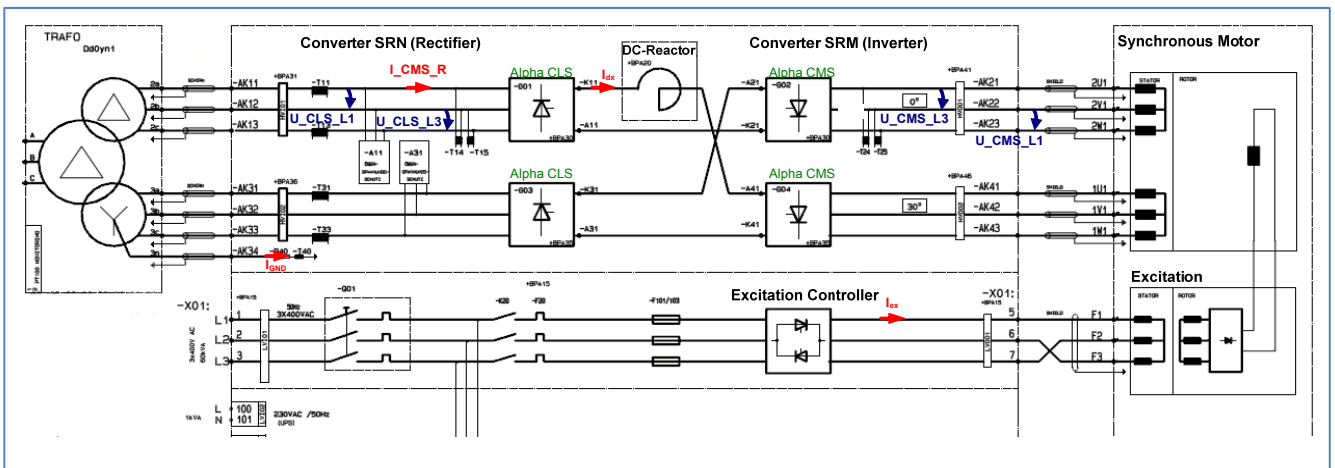

Figure 1 - Frequency converter layout. The labels are the points of measurement

The figure above shows the block diagram of the frequency converter of a Blast Furnace Blower system. An Elsys transient recorder collects the various signals mostly through the drive system's control electronic. The control electronic block is the signal conditioning interface that probes the signals labeled in the diagram Figure 1 and provides access to a normalized voltage signal and is limited in bandwidth to 5-40 kHz.

Instrumentation

The data acquisition system currently used for the monitoring measurements is an Elsys transient recorder TraNET 404S. This instrument has 16 analog input channels with a sample rate of up to 80 MS/s and a record length of 16 MS per channel. The TraNET is configured in the Event Controlled Recording (ECR) data acquisition mode. Each of the 16-channels can be configured as an active trigger source in OR trigger logic. There are three different configuration types in the ECR-mode: SingleChannel-mode, SingleChannel-mode with associated channels and Multi-Channel-mode. In SingleChannel-mode just the triggered channel captures the event and stores it to the internal hard disk drive whenever one of the input channels meets the trigger conditions. This is a unique data acquisition mode that can be configured to acquire the relevant events on the triggered channel only if required. In case it is important to capture also related signals synchronously at exactly that time, the Single Channel mode with associated channels is the right choice. Sometimes all signals need to be acquired if the event occurs. In this case the Multi-Channel event controlled recording is the suitable data acquisition mode.

The data recording instrument TraNET 404S was selected for this application because of its 16 input channels, the ECR data acquisition mode and the large memory depth.

Instrument Setup

The next figure shows the data acquisition configuration of the Elsys TraNET 404S for this application:

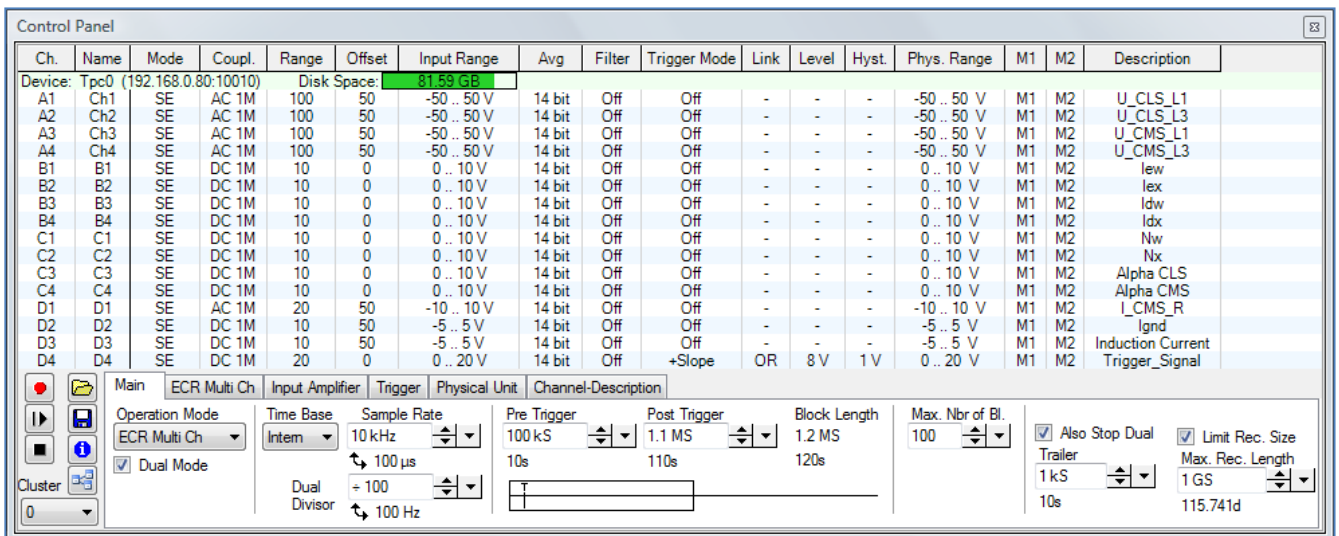

Figure 2 - Signals & Settings of the TraNET 404 with channels 1-16. Note: Some signals like speed, nw, nx and references '...w' are control signals that cannot be displayed in the diagram Figure 1

In this specific measurement task the TraNET 404S data recorder is operating stand alone in the ECR Multi Channel Mode with the Dual Mode activated. This means that all the 16-channels are continuously acquiring the data-stream to disk at a sample rate of 100 S/s once the recording is started. As soon as the trigger condition is met on the only trigger source D4 the instrument acquires on all the 16-channels 100 kS before the trigger event and 1.1 MS after the trigger event at a sample rate of 10 kS/s. This procedure goes on in a loop until 100 blocks are acquired. The continuously sampled acquisition of the Dual Mode stops either 10s after the last block was acquired or in case the maximum limit is reached. In this setup the Dual part would stop after 115.741 days of streaming to hard disk of all the 16-channels at 100 S/s.

IT-Network

The ABB VFD System is monitored by the TraNET 404A via the Transient Recorder software TransAS 3 either from local- or remote computer. In both ways TransAS 3 allows to configure the Transient Recorder and to read and display the captured waveforms without physically accessing the unit. The next figure gives an overview how the Transient Recorder installed in a customer network can be accessed either from the ABB office or a local PC in the customer network.

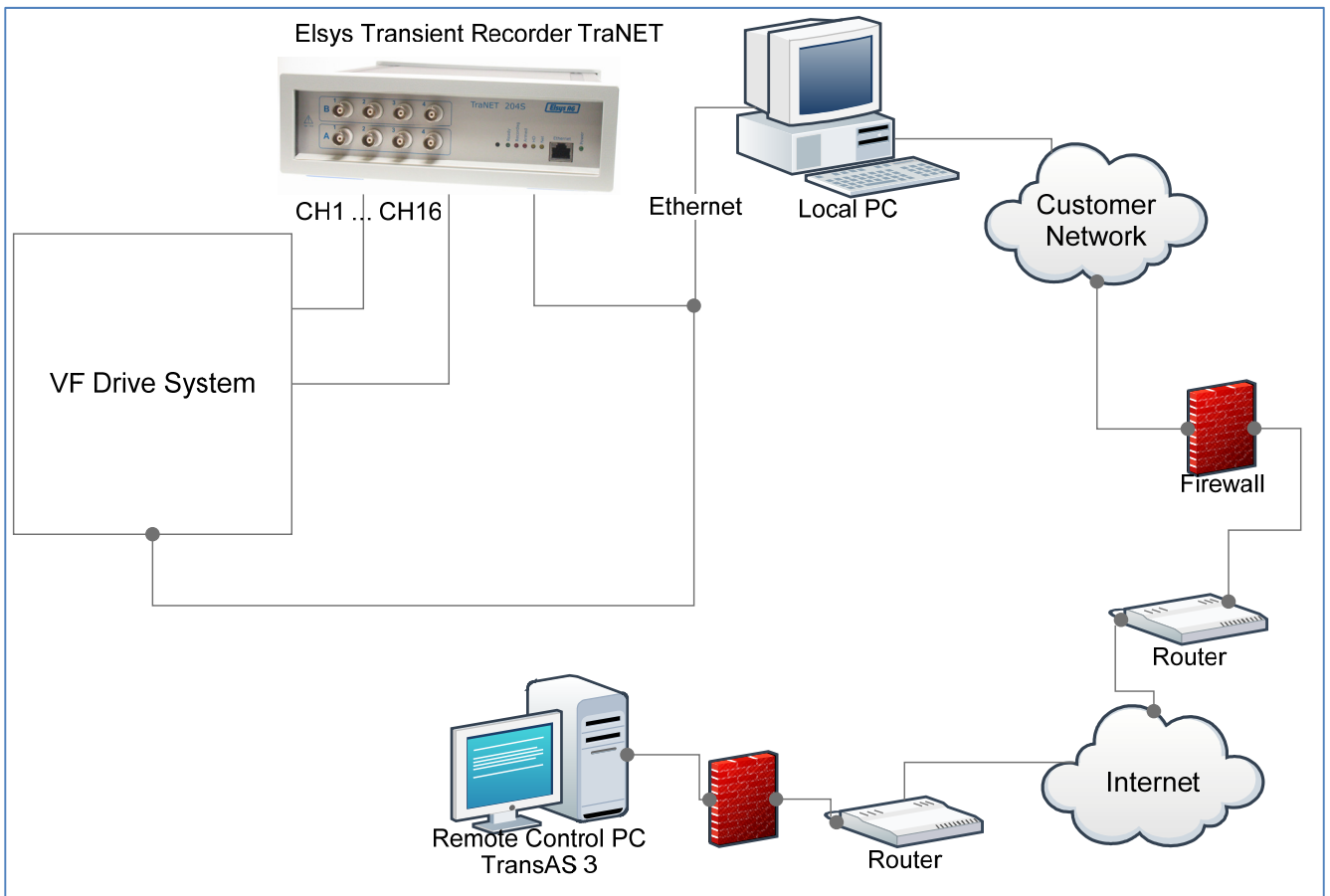

Figure 3 – The ABB VF Drive System is monitored either from local- or remote computer

Sample Waveforms

In the sample acquisitions shown below is a snapshot of a long acquisition over hours where just a few trigger events are displayed. In this specific application, the trigger pulse was generated by the drive system. The vertical white line **T** is indicating the trigger time. In total 6- of the 16 channels are displayed in the waveform graph. The legend in the upper right corner is listing the channel names in reference to the control panel shown in Figure 1. The waveform graph is arranged with four different vertical axes in order to display the various traces in different scaling.

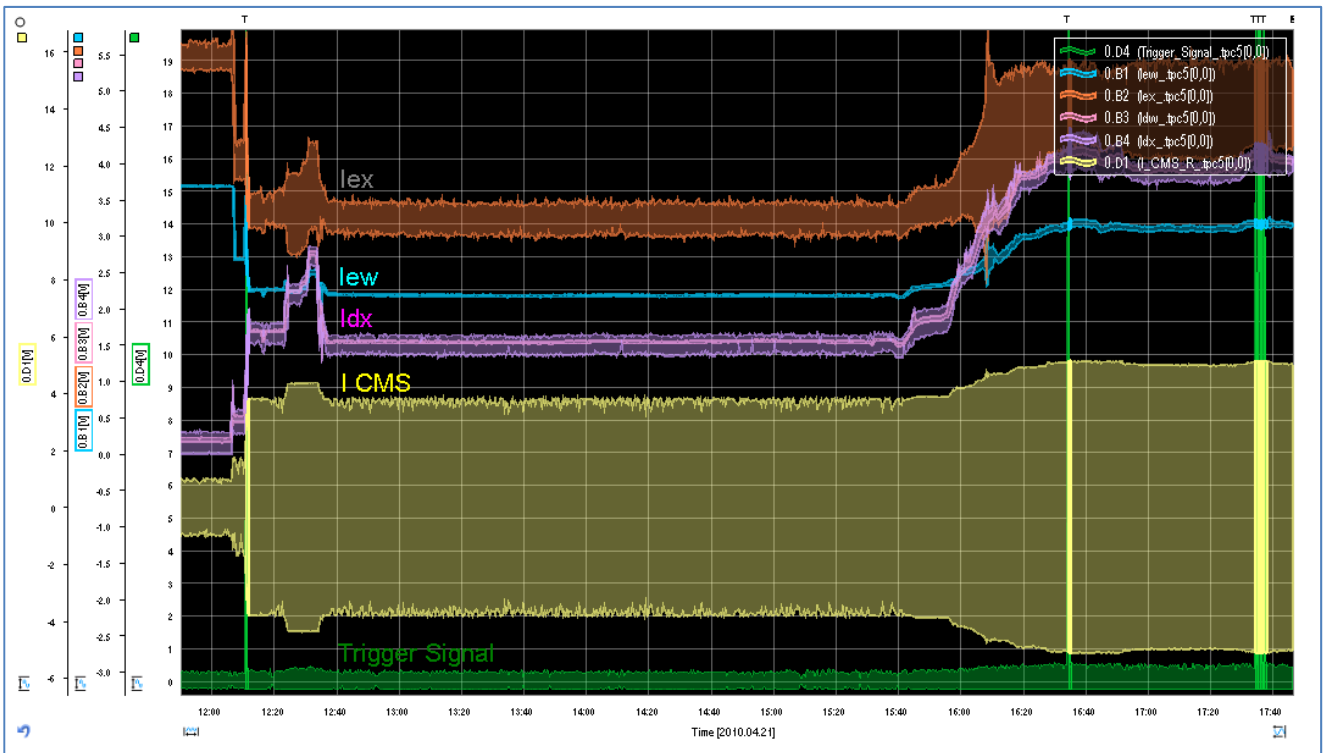

Figure 4 – Some events captured of the drive system measurements with the low speed sampled continuous waveform and the fast sampled events in absolute time. Note the time between events of several hours.

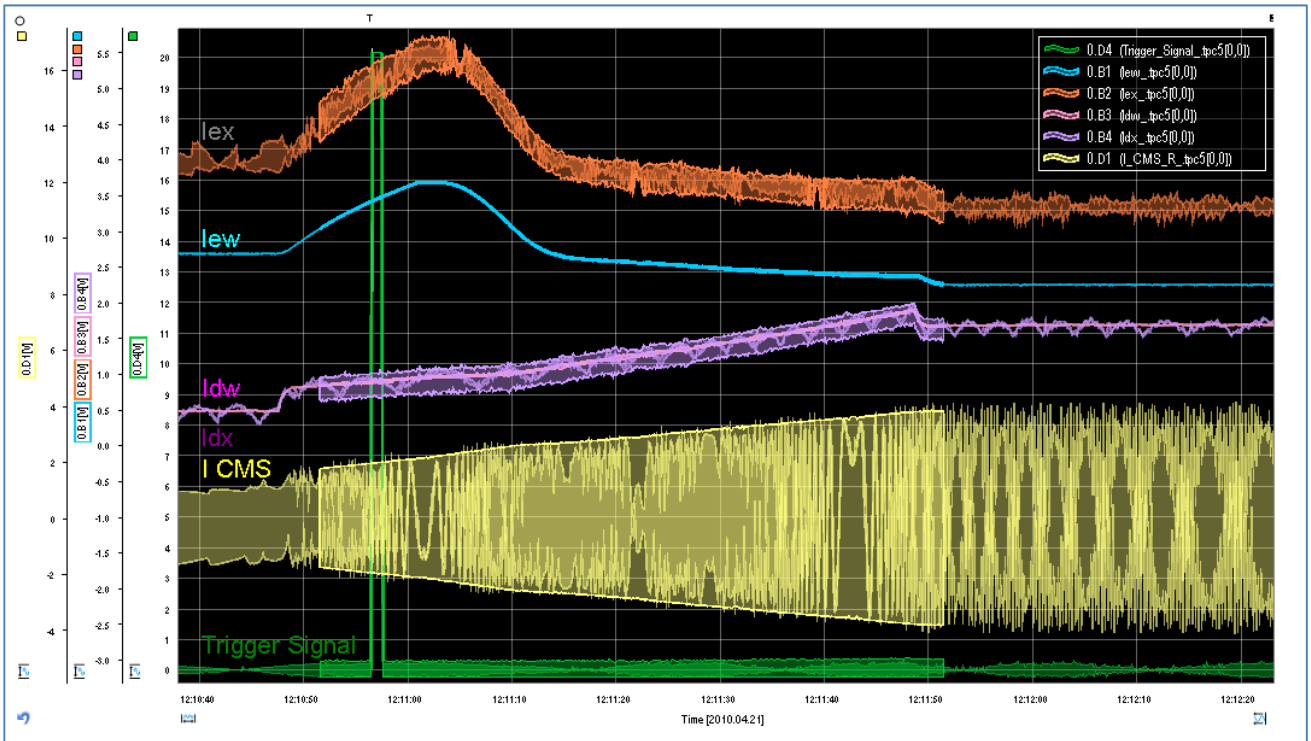

Figure 5 – A zoom in to the event shortly before 12:11. More details are revealed of the waveform shapes displayed in envelope mode.

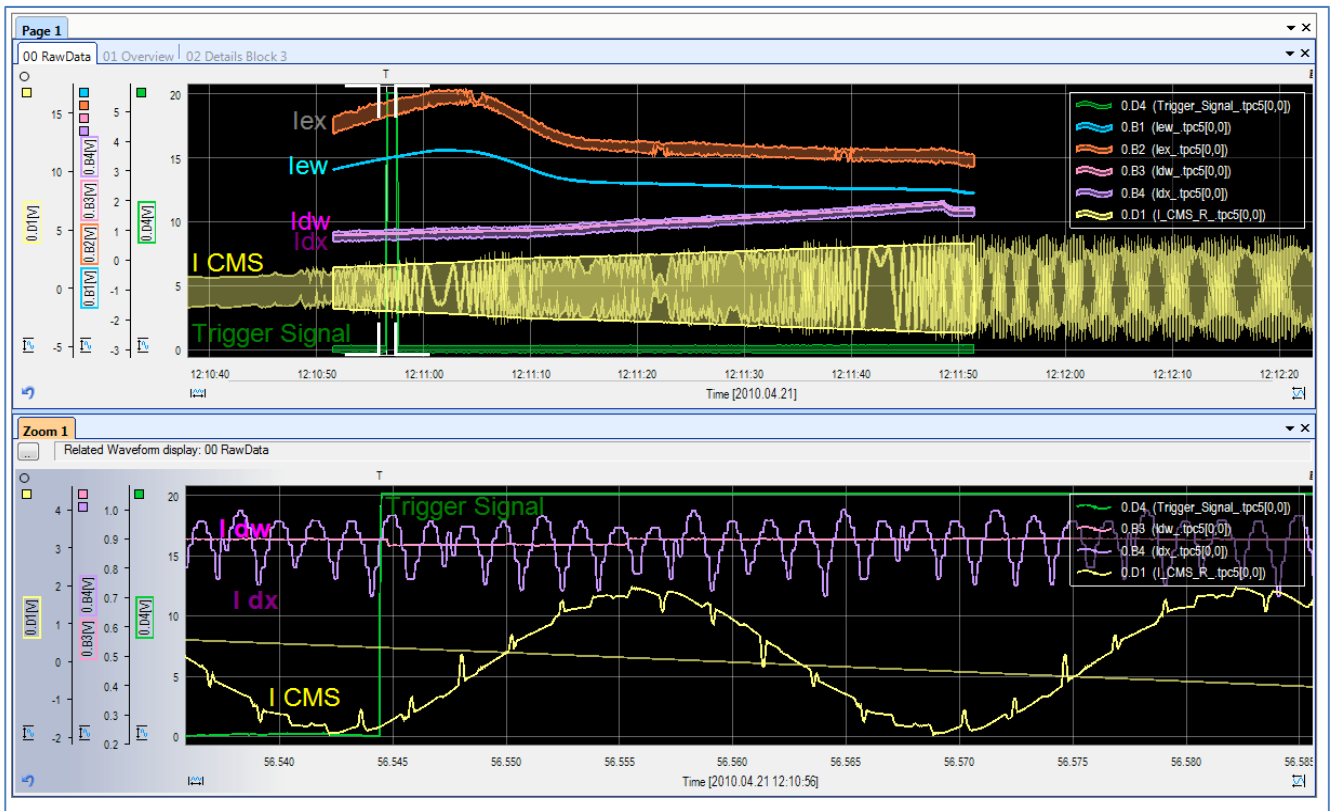

Figure 6 – The fast sampled events are shown in the upper graph (D1- I_CMS_R including the slow sampled trace). In the lower graph some zoomed traces are shown to reveal the waveform shape. The zoomed region in the window Zoom 1 is indicated in the upper graph by white brackets.

Summary

It is very important to capture the events from the variable frequency drive system over a long period of time and to display the events and the continuous background signal in an effective and flexible way. To have easily access to the relevant information in the monitored data acquisition allows an efficient diagnosis of unwanted phenomena.

The unique combination of fast sampled events and the slow sampled continuous waveform in the ECR data acquisition mode enables ABB Switzerland to not only monitor but also troubleshoot an installed customer converter drive system. The fact that this is even possible from the application engineer’s desk is an added value and avoids the need to go on-site in many cases.